

# SCL2

## Round LED Mini Panel Light



Selectable Wattage Switch and Integrated Occupancy/Photo cell Sensor Shown



### Key Features

- Versatile LED mini panel light designed for both new construction and retrofit projects.
- Selectable switch for wattage options.
- Integrated occupancy/photo cell sensor.

### Electrical

- 120-277VAC 50/60Hz input.
- Power factor: >0.50 and THD <20%.
- Operating temperature: -30°C to 40°C (-22°F to 104°F).

### Mounting

- Housing is configured for mounting directly over a standard 4" outlet box (by others) or surface mounted using provided hardware.

### Construction

- Diffused lens helps to provide comfortable, uniform light distribution.
- Trim ring is a white matte finish. Consult factory for other color finishes.

### Optics

- Industry-leading LEDs with 4000K and 5000K CCT (minimum 80 CRI).
- 360° field of view
- Lumen Maintenance: 30,000 hours (L70) <sup>1</sup>

### Warranty

- Backed by US LED's Three-Year Warranty.

Project	Date
---------	------

Catalog Number	Type
----------------	------

### Product Performance Summary

Lumen Output	Up to 1,987 lumens
Efficacy	Up to 121 LPW
CRI	≥ 80 CRI
Available CCT	4000K & 5000K
Warranty	Three-Year Warranty

### Product Overview

With a low-profile design and stay-white acrylic diffuser, the SCL2 is the perfect solution to illuminate smaller commercial applications like self-storage units, utility areas, and other similar spaces. The SCL2 is available in a slim 9" round model and offers selectable wattage options.

### Product Applications

- Self-Storage Units
- Utility Areas
- Hallways/Corridors
- Workrooms
- Closets
- General Lighting

### Product Certifications

- ETL Listed
- Complies with UL1598 and CSA 22.2
- RoHS compliant



### Ordering Information

Example: SCL2-9-UNVL-10-50-WH

SCL2					
Series	Size	Input Voltage	Selectable Power	CCT	Trim Color
9	9" Round	UNVL 120V-277V	10 10W, 15W, 18W	40 4000K 50 5000K	WH White

1. US LED product 'Lifetimes' refer only to the LED light engine, not the power source, and are based on the Illuminating Engineering Society's TM21 Projected Lumen Maintenance methodology at a 25° C / 77° F ambient temperature. The lifetimes are solely meant to be a guide for expected LED degradation and not a warranty or predictive of their actual life, which can be affected by ambient temperatures and other factors.

# SCL2

## Round LED Mini Panel Light

### Dimensions

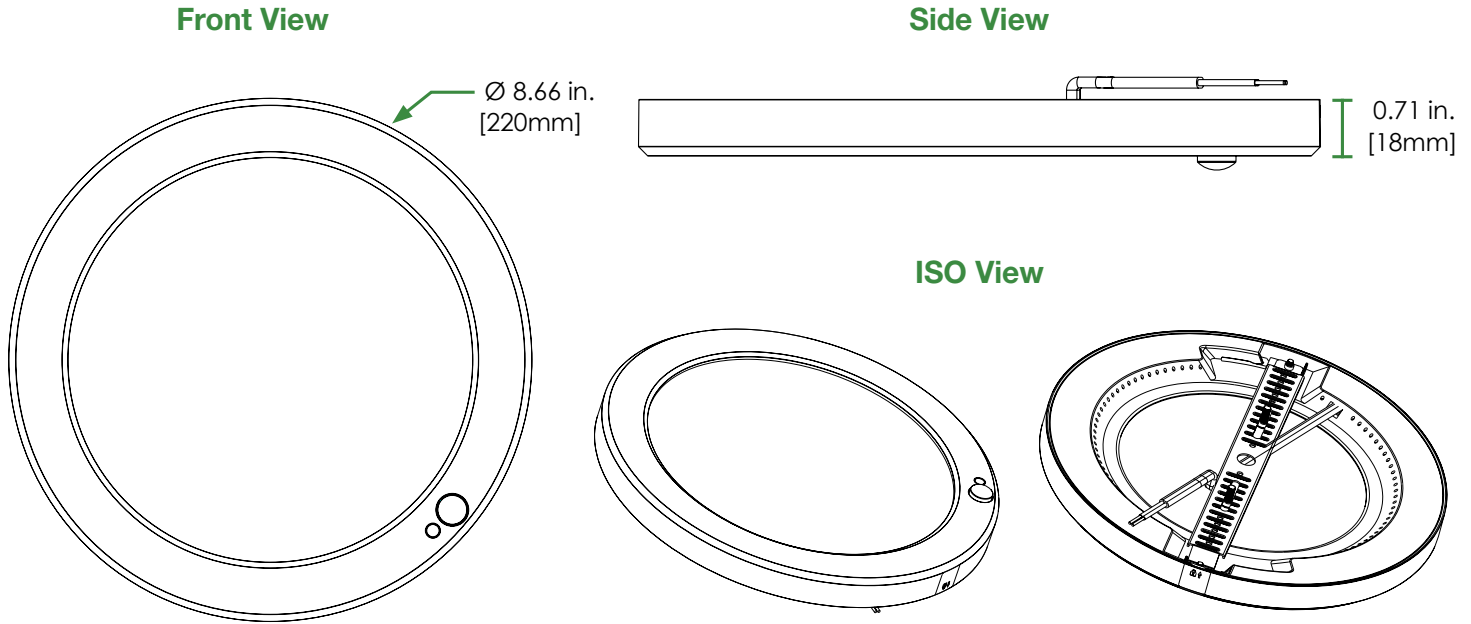

### Performance Data

Model	Diameter Size	System Level Power	Delivered Lumens	Efficacy	Available CCT	L70 Calculated Life
SCL2-9-UNVL-10-XX-WH	9" Round	10W	1,213	121 LPW	4000K/5000K	30,000 Hours
	9" Round	15W	1,693	113 LPW	4000K/5000K	30,000 Hours
	9" Round	18W	1,987	110 LPW	4000K/5000K	30,000 Hours